

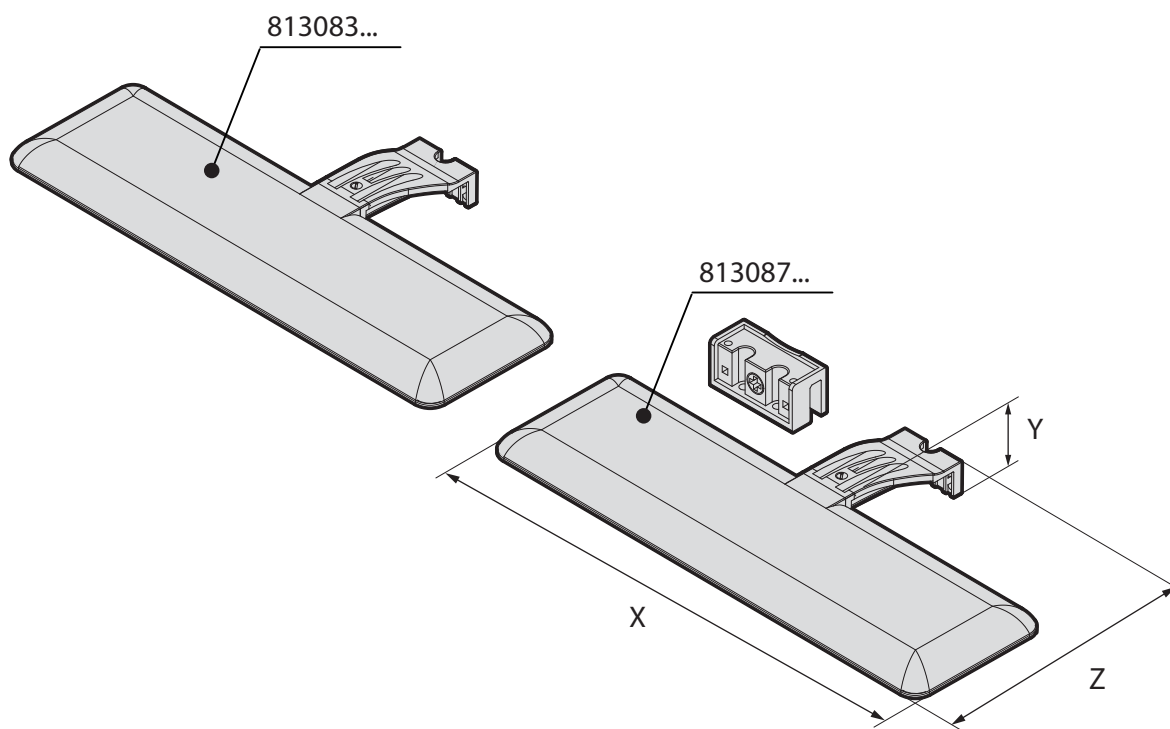

## MOONLIGHT

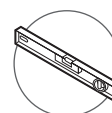

	mm		
	X	Y	Z
813083...	300	32	161
813087...	300	32	161



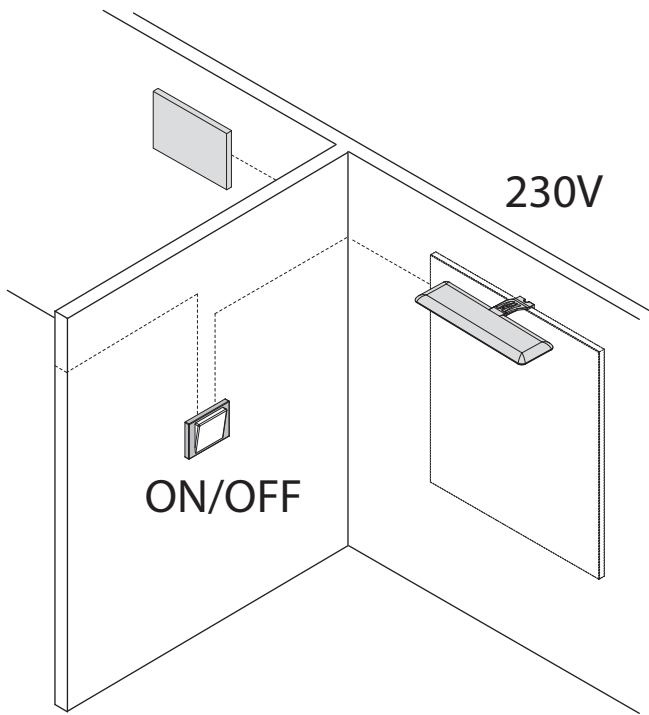

220-240V ~ 50/60Hz

LED Max 1x10W

IP44   CE 

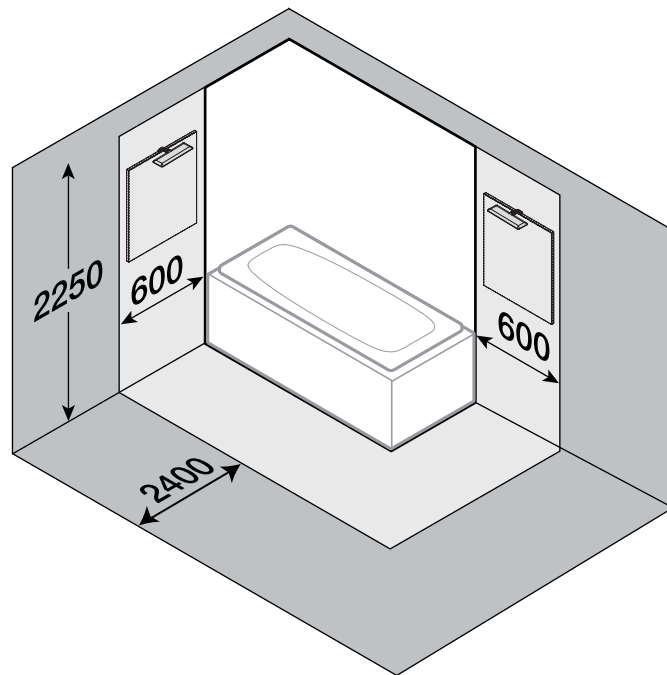

L min. 2 x 1mm <sup>2</sup>

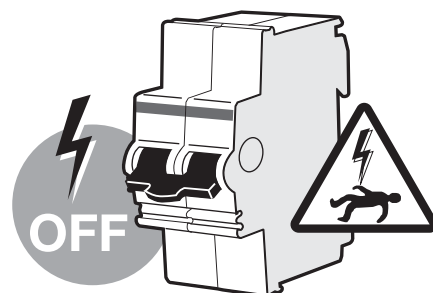
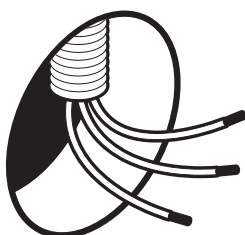

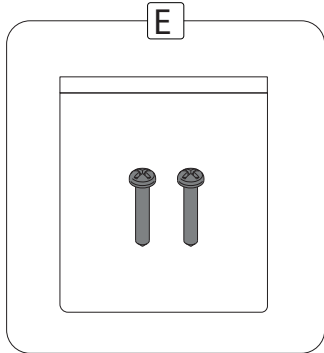
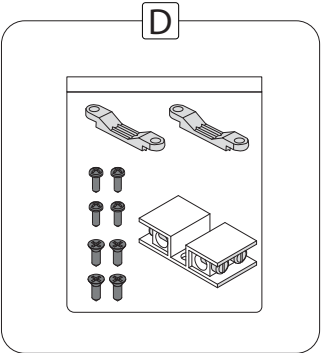
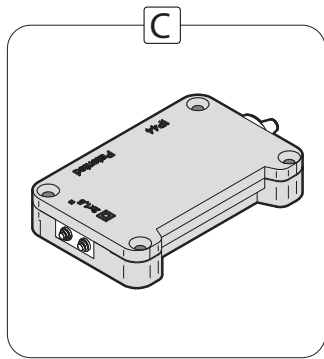
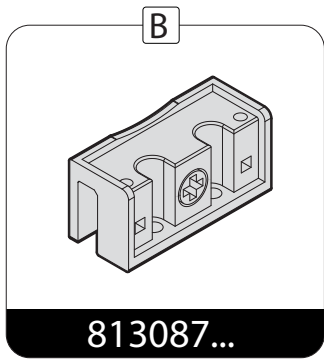
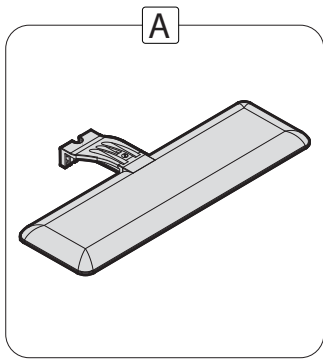

1

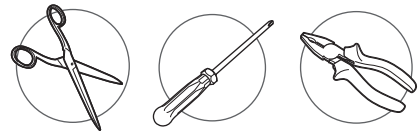
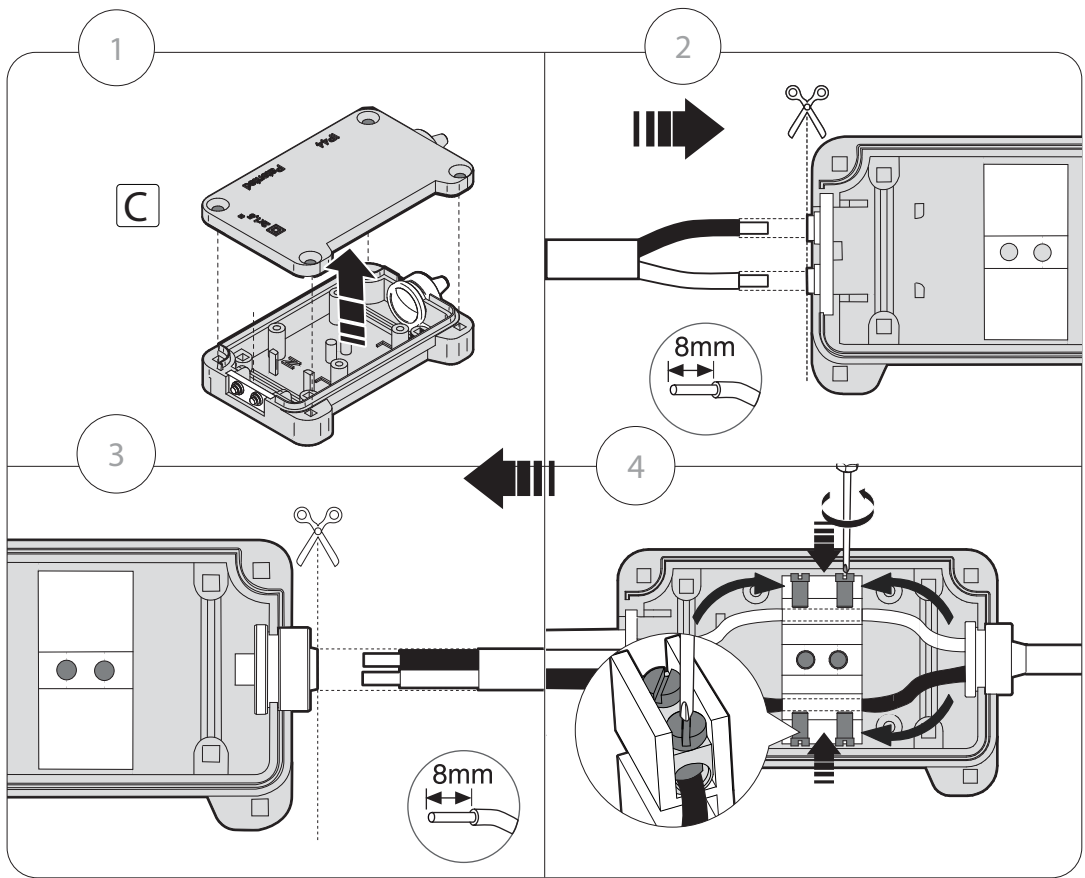

1

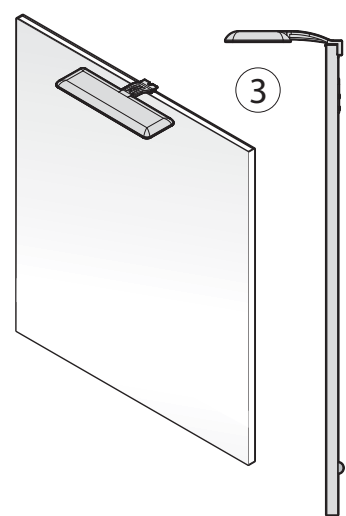
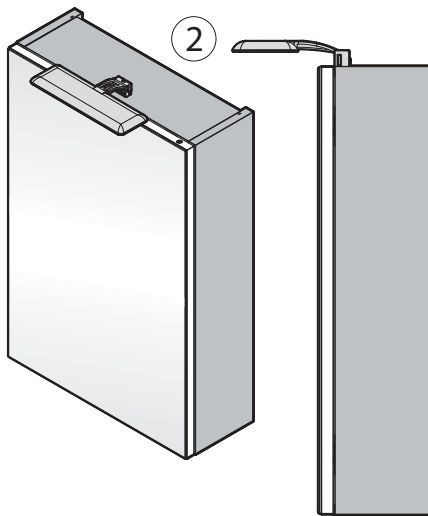
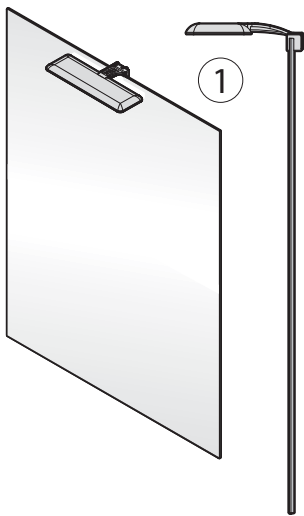
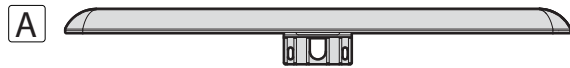
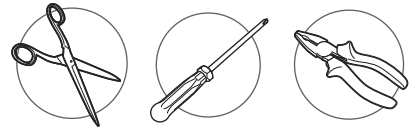
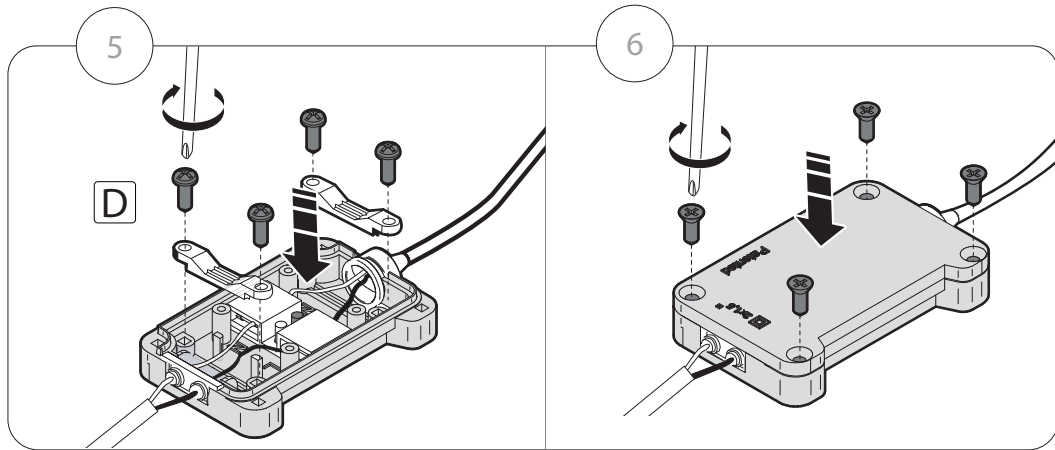

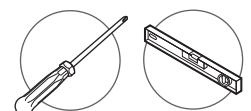
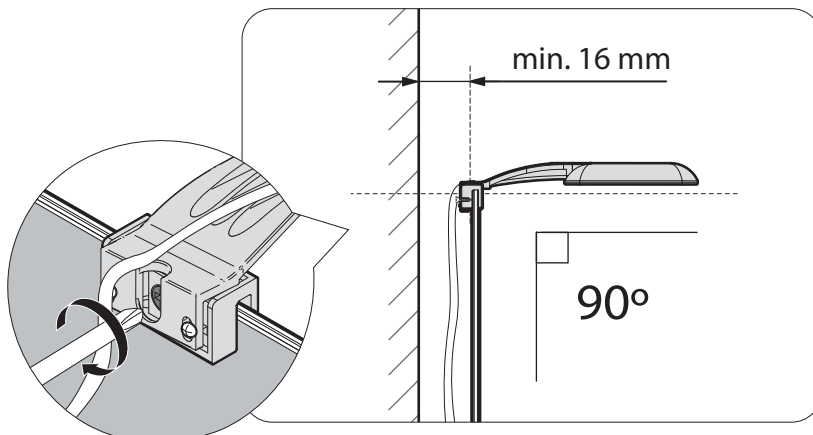
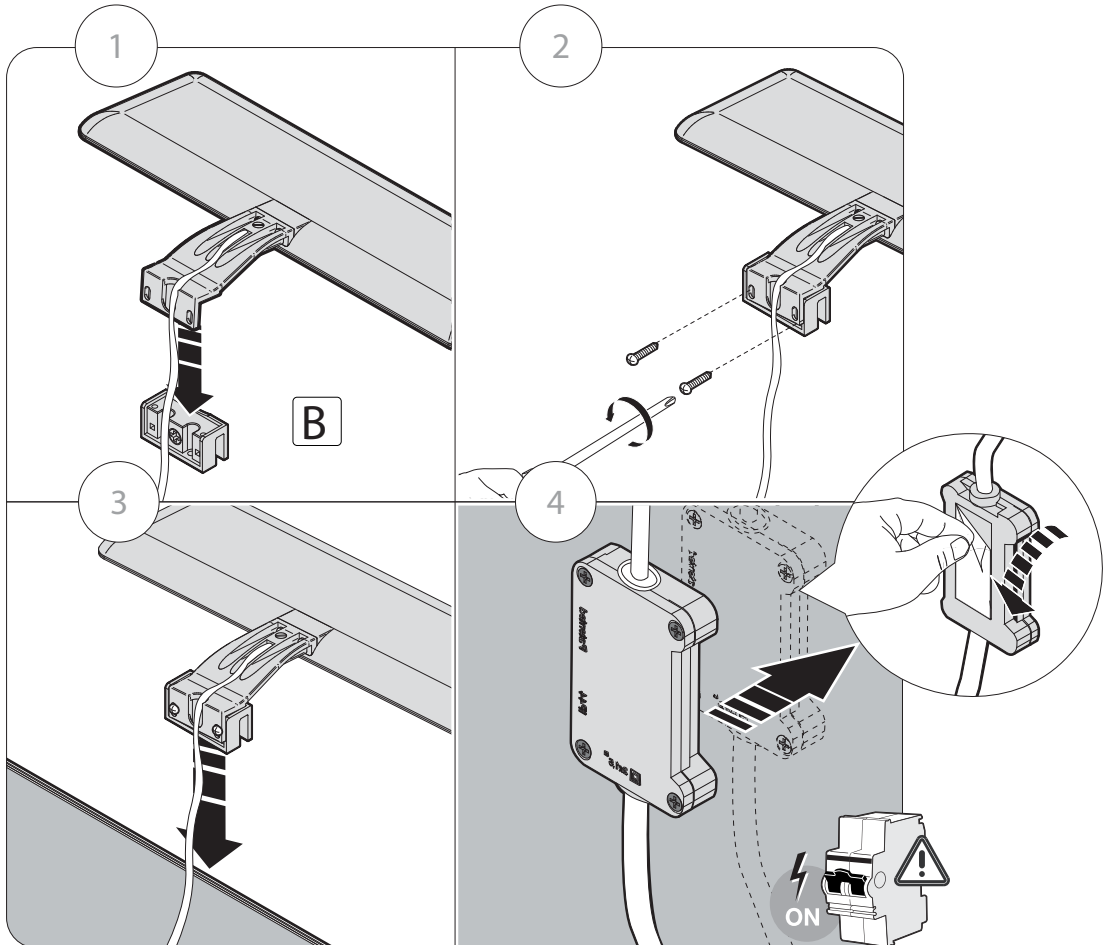
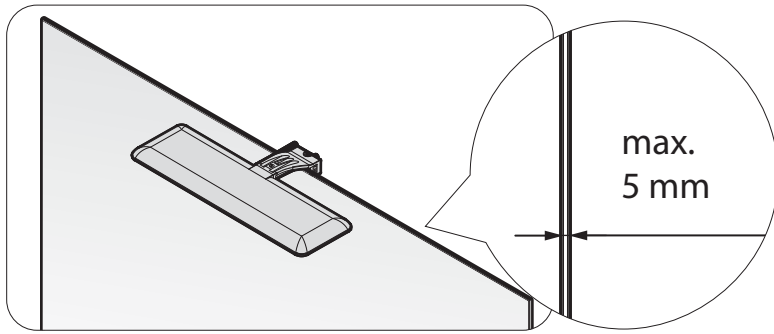
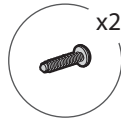
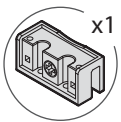

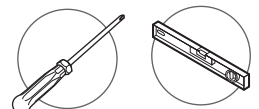
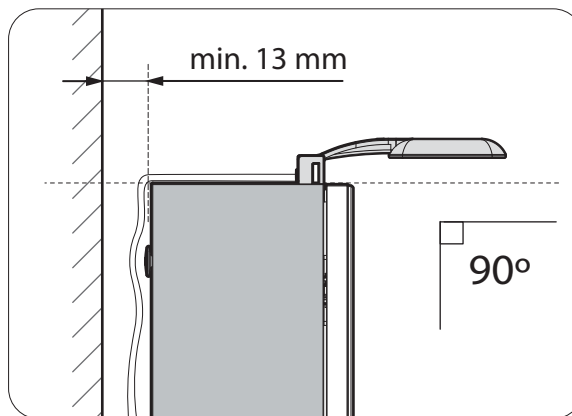
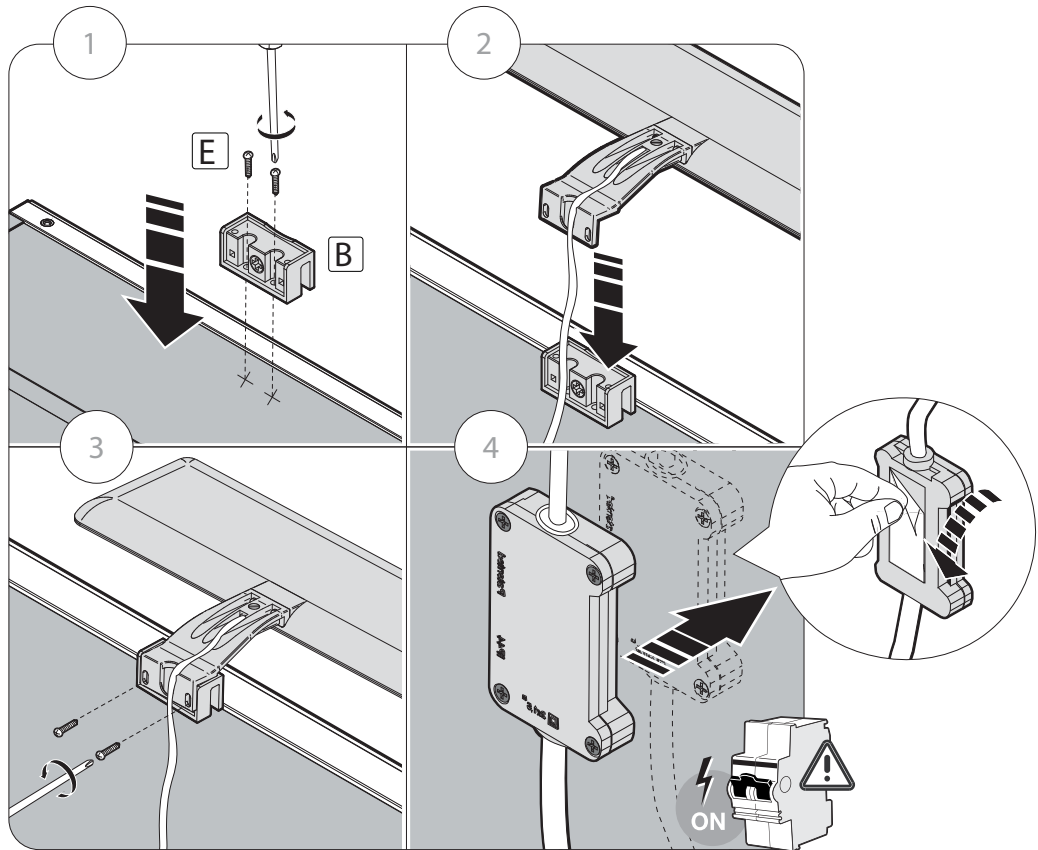
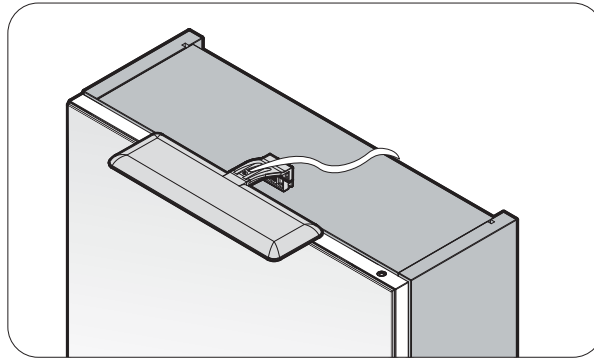
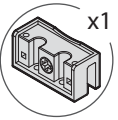

2

OPTION 3

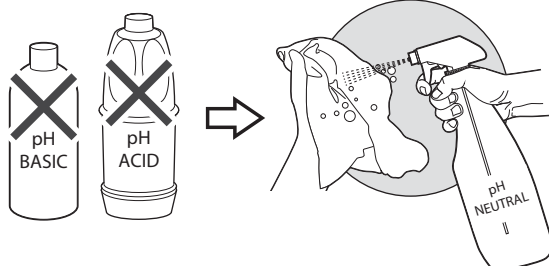
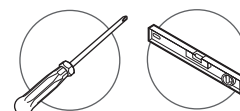
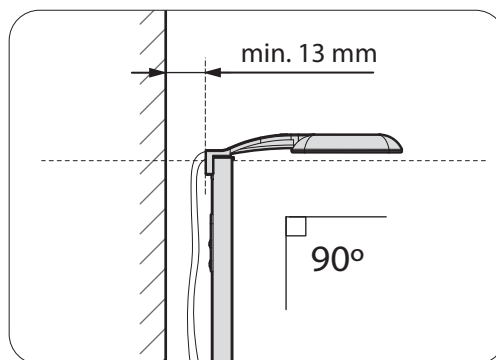
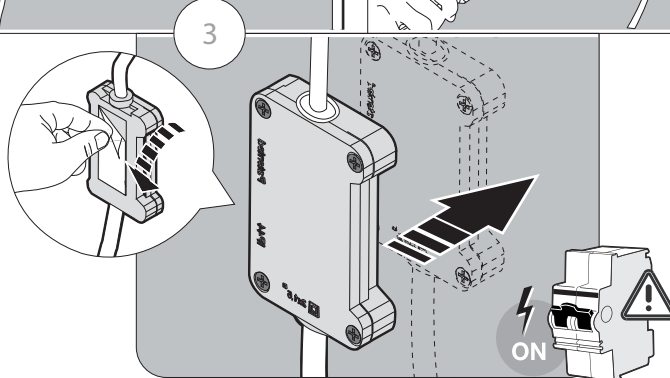
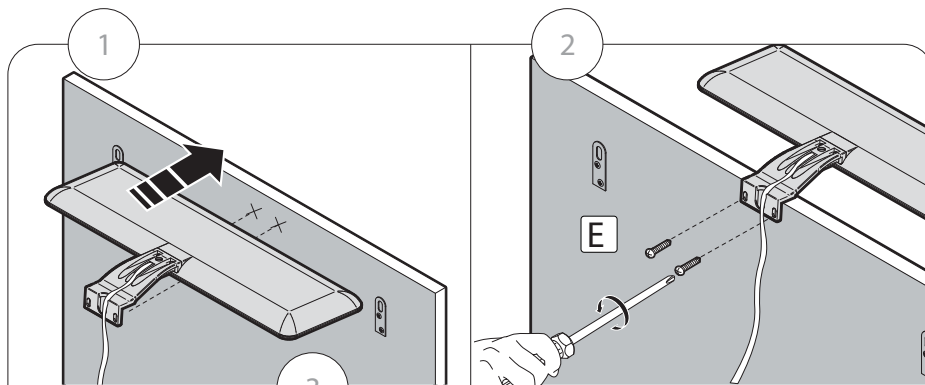
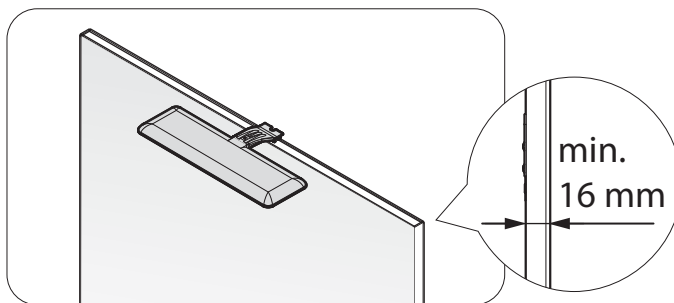

Must be cleaned with NEUTRAL pH cleaning product





## Eliminación de aparatos eléctricos y electrónicos

NOTA: Este símbolo y sistema de reciclado es de aplicación únicamente en la Unión Europea. NO aplica en el resto del mundo.

En ROCA estamos comprometidos con la protección del medio ambiente. Por favor, ayúdenos desechando este producto al final de su vida de forma responsable, para evitar que determinadas sustancias contenidas en los productos eléctricos o electrónicos puedan causar perjuicios en la salud humana y en el medio ambiente.

El símbolo del contenedor de basura tachado, reproducido arriba y sobre el producto, significa que el mismo no debe ser desechado junto con otros residuos domésticos. Al final de la vida del producto, el mismo deberá ser entregado en las instalaciones de recogida habilitadas al efecto por las autoridades de su país o al distribuidor en el que adquiera un nuevo producto equivalente o que realice las mismas funciones que este aparato. Esta última opción puede no estar disponible en algunos países, por lo que le rogamos consulte con las autoridades de su país los sistemas de recogida disponibles y los puntos de recogida más cercanos a su domicilio.

De este modo, Vd. puede colaborar con la protección del medio ambiente gracias a la reutilización y el reciclado de residuos de aparatos eléctricos y electrónicos. Por el contrario, pueden derivarse para Vd. responsabilidades administrativas en caso de incumplimiento de las normas de entrega del residuo de este producto.

Las baterías deben ser extraídas previamente y depositadas separadamente en contenedores de reciclaje adecuados.



## Disposal of electric and electronic products

NOTE: This symbol and recycling system is only applicable in the European Union. It does NOT apply to the rest of the world.

At ROCA we are committed to protecting the environment. Please help us by discarding this product at the end of its life-cycle in a responsible manner, to prevent that certain substances contained in electrical or electronic equipment may cause harm to human health and the environment.

The crossed-out wheeled bin symbol, shown above and on the product, means that such product should not be discarded with other household waste. At the end of the product's life-cycle, it must be delivered to the corresponding collection facilities enabled by the authorities in your country or to the supplier from which you purchase a product of equivalent type or that fulfills the same functions as the previous equipment. This last option may not be available in some countries, so please check with the authorities in your country about the collection systems available and the collection facility closest to your home.

This way, you can cooperate with the protection of the environment through the reuse and recycling of waste electrical and electronic equipment. On the contrary, administrative responsibilities can be derived for you in case of non-compliance with the rules for the delivery of the waste of this product.

Batteries shall be previously removed and discarded separately in suitable recycling containers.

DIN A4

**Roca**

Roca Sanitario, S.A.  
Avda. Diagonal, 513  
08029 Barcelona  
SPAIN  
www.roca.com

**933  
661  
266**

LÍNEA DE ATENCIÓN  
AL CONSUMIDOR  
ESPAÑA  
SERVICIO TÉCNICO  
ESPAÑA



productsupport.rs@roca.net  
soporteproducto.rs@roca.net

Q40600153G-d